

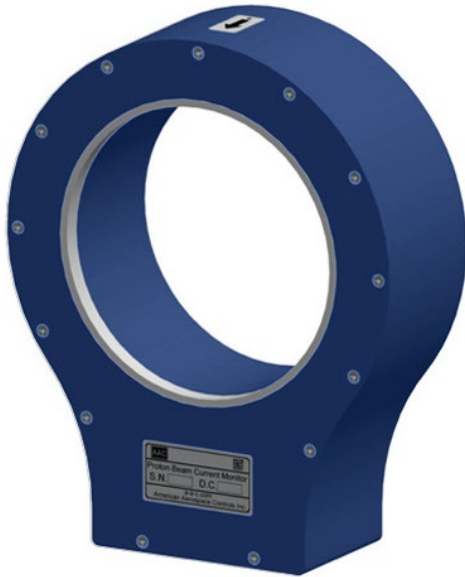

CHARGED PARTICLE BEAM CURRENT SENSOR

BCS-01

Fast response, DC – 140 kHz beam current sensor for non-intercepting charged particle beam current measurements¹.



- Non-intercepting current transformer
- Fast response time (< 2.5 μ s)
- No Droop
- Accuracy < \pm 1% Full Scale (FS)
- DC to 140 kHz bandwidth
- Analog design
- Self contained package
- Beam energy range: eV - GeV

SPECIFICATION: BCS-01

INPUT CURRENT	
MEASUREMENT RANGE ²	\pm 25 mA to \pm 200 mA
OVERLOAD	500 mA
OUTPUT	
VOLTAGE SIGNAL	\pm 2 or \pm 5 V at max current range
ACCURACY (5-20 mA)	\pm 1% (@ +20°C to +30°C)
LINEARITY ERROR (5-20 mA)	< 0.1%
RIPPLE	0.5% FS RMS max
OUTPUT IMPEDANCE	400 Ω
RESPONSE	2.5 μ s max (10-90% FS)
BANDWIDTH (-3dB)	DC to 140 kHz
POWER SUPPLY	
SUPPLY VOLTAGE	\pm 15 V DC \pm 1 V
CURRENT DRAIN	50 mA DC max
REVERSE POLARITY PROTECTION	10 μ A max current drain-no damage

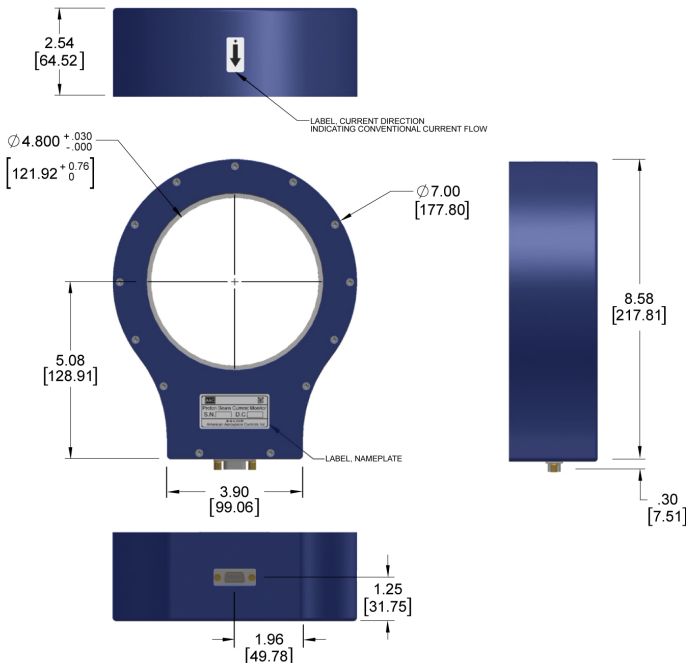

TERMINAL IDENTIFICATION

1. SUPPLY VOLTAGE (+)
2. SUPPLY VOLTAGE (RTN)
3. SUPPLY VOLTAGE (-)
4. OUTPUT SIGNAL (+)
5. OUTPUT SIGNAL (RTN)
- 6-8. SPARE
9. SHIELD GND

9 PIN D-SUB CONNECTOR

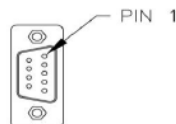

MATING CONNECTOR
P/N: SPC15411

OPERATION

BCS-01 installs over a ceramic vacuum break along a customer's beamline. The unit measures the beam's DC and time-varying signals separately and then combines both signals to provide an analog output proportional to the beam current.

APPLICATIONS

There is a large demand in the medical field for beam therapy equipment for which the Charged Particle Beam Current Sensor is a perfect fit. Many applications have already benefited from the reliability and performance of this sensor.

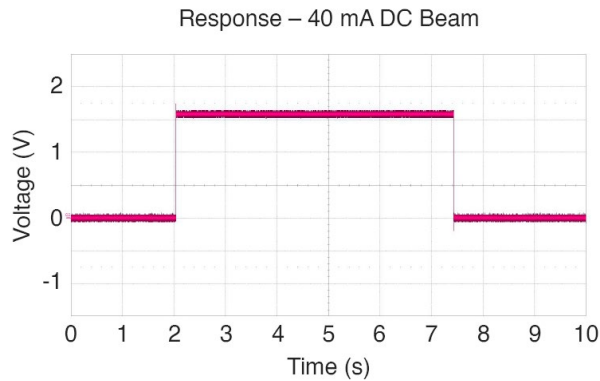
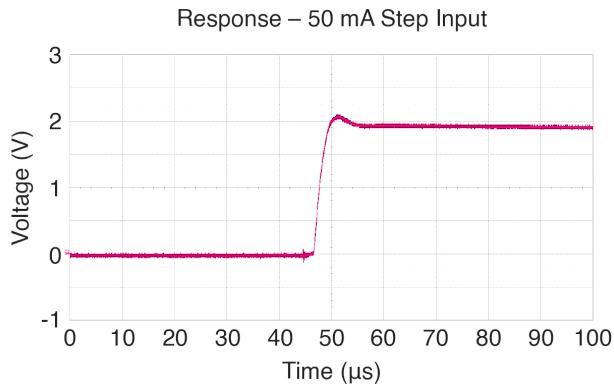

ENVIRONMENTAL AND PHYSICAL CHARACTERISTICS	
OPERATING TEMPERATURE RANGE	-40°C to +70°C
STORAGE TEMPERATURE RANGE	-40°C to +85°C
INSULATING RESISTANCE	> 100 MΩ
DIELECTRIC STRENGTH	350 V DC (terminals 1 through 8 to 9 & case)
SHOCK	Operating 50 g, 11 ms half -sine pulse Method 213 Condition A of MIL-STD-202
MOISTURE RESISTANCE	Meets Method 106 of MIL-STD-202 and Method 507.1 Proc. 1 of MIL-STD-810
OPERATING HUMIDITY	0 to 95% RH
ATTITUDE	Meets specification for any mounting orientation
WEIGHT	2.27 kg Max

PACKAGE OPTIONS

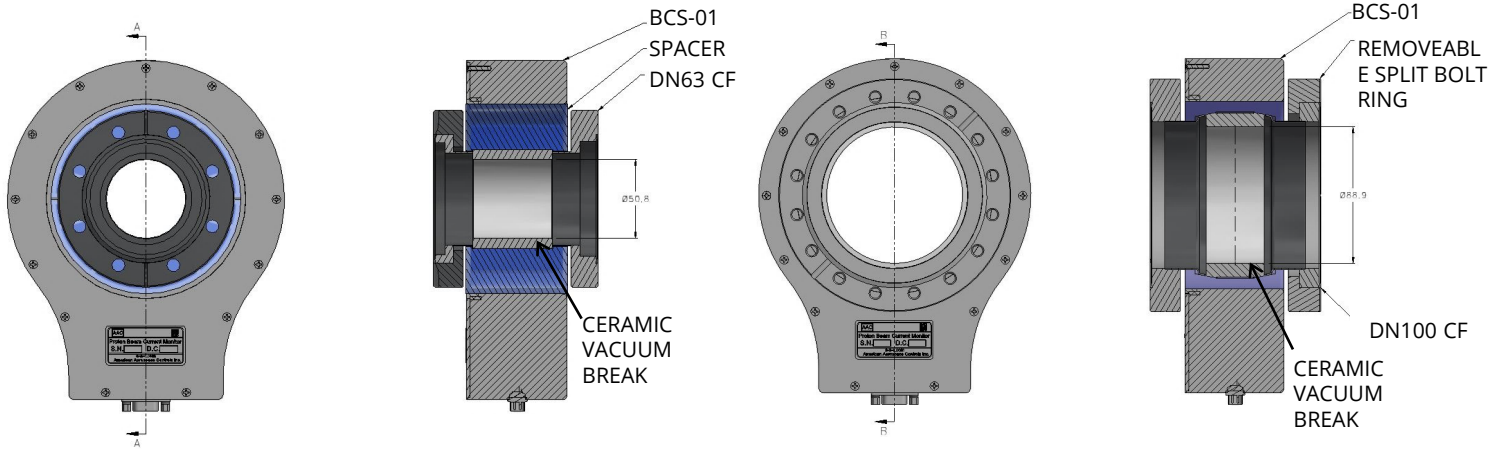

OPTION A: FOR SMALLER BEAMPIPES

This option is for beampipes which have flanges smaller than the internal diameter of the BCS-01. A ceramic vacuum break and a spacer will be included with the sensor. The BCS-01 will be held in place over the vacuum break by the polymer spacer.

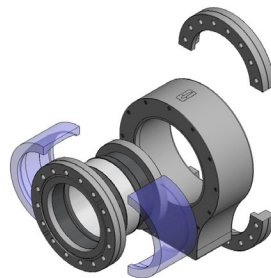

OPTION B: FOR LARGER BEAMPIPES

This option is for beampipes which have flanges larger than the internal diameter of the BCS-01. A ceramic vacuum break with a removable split bolt ring and a spacer will be included with the BCS-01. The split ring will allow the vacuum break to fit through the BCS-01. The BCS-01 will be held in place over the vacuum break by the polymer spacer.

1. American Aerospace Controls' (AAC) technology product.
2. Measurement range (i.e. ±25 mA, ±50 mA, ±100 mA, etc.) is configured during manufacture and must be specified when ordering.